



SISTEMAS EMBARCADOS

Petiano: Yuri Gonzaga G. da Costa





ÍNDICE



- História
- O que são Sistemas Embarcados?
- Exemplos e Aplicações
- Arquitetura Conceitual
- Implementação de Projetos
- Futuro dos Sistemas Embarcados

A decorative graphic on the left side of the slide, consisting of three colored circles (dark teal, light teal, and grey) and a vertical line to their right.

HISTÓRIA

- Décadas de 30 e 40:
 - Primeiros computadores possuíam funções específicas.
- Décadas de 60 e 70:
 - Apollo Guidance Computer (AGC) – Considerado o primeiro Sistema Embarcado Moderno.

HISTÓRIA

- AGC montado no painel de controle da Apollo.



- Interface do AGC

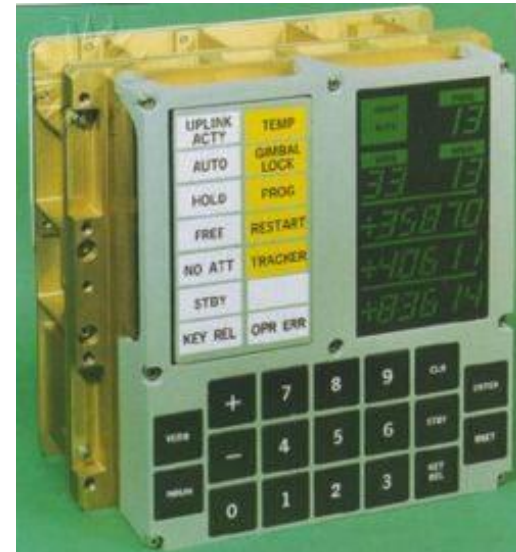



HISTÓRIA



- Autonetics D-17 – Computador guia do míssil Minuteman - Primeiro Sistema Embarcado produzido em massa.
- Desenvolvimento da Indústria de CI's. Um NAND que custava \$1000 passou a custar \$3.

HISTÓRIA

- Décadas de 70 e 80:
 - Surgimento e expansão dos primeiros Microprocessadores e microcontroladores.
- Décadas de 90 até os dias de hoje:
 - Redução dos custos / aumento do poder de processamento e funcionalidade.

HISTÓRIA

- Alguns processadores foram e ainda são amplamente utilizados, como o Z80 (8 bits), Motorola 68000 (16 bits) e os chips ARM (32 bits), em video-games, DVDs, Palms, injeção eletrônica, etc.



PET
.COM

ASID

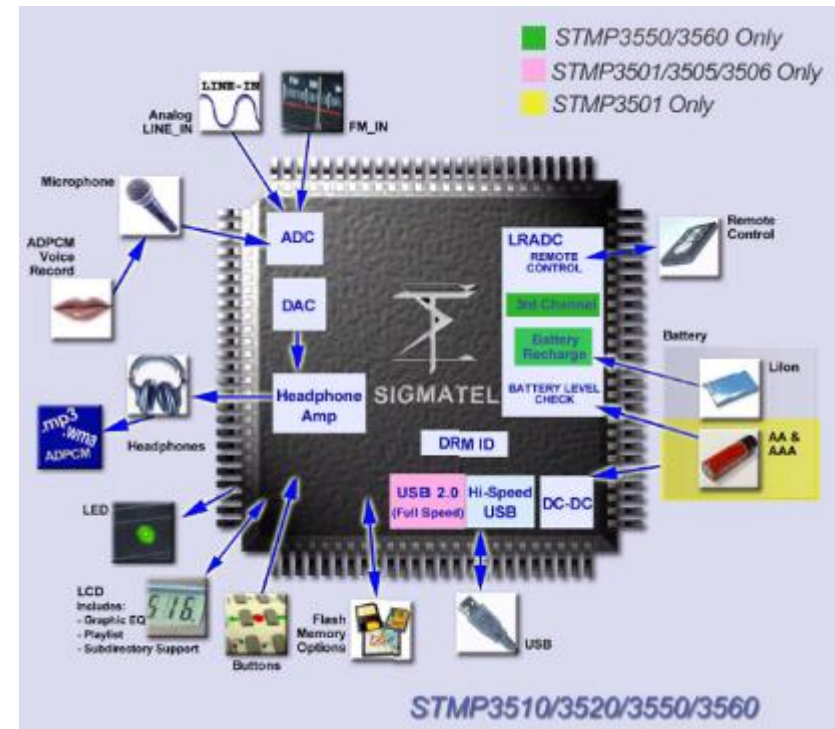



O QUE SÃO SISTEMAS EMBARCADOS?

- Conceito inicial:
 - Um sistema embarcado, ou sistema embutido, é um sistema microprocessado no qual o computador é completamente encapsulado ou dedicado ao dispositivo ou sistema que ele controla.
 - Difere de outros sistemas computacionais, como os PCs e os supercomputadores.



O QUE SÃO SISTEMAS EMBARCADOS?



- Um sistema embarcado realiza um conjunto de tarefas pré-definidas, geralmente com requisitos específicos.
- Já que o sistema é dedicado à tarefas específicas, pode-se otimizar o sistema reduzindo tamanho, recursos computacionais e custo do produto.



O QUE SÃO SISTEMAS EMBARCADOS?



- Devido aos constantes avanços na tecnologia e a queda nos custos de implementação tanto de componentes de software como hardware, a definição de Sistemas Embarcados está em aberto.
 - Alguns sistemas, como celulares, Palms, PDAs e TV Digital, estão se tornando bem completos, fugindo ao conceito inicial.



O QUE SÃO SISTEMAS EMBARCADOS?



- Descrições atualmente contestadas:
 - Sistemas Embarcados são mais limitados em funcionalidades de hardware e/ou software que um PC.
 - Sistemas Embarcados são desenvolvidos para executar tarefas específicas.
 - É requerido maior qualidade e confiabilidade dos Sistemas Embarcados que de outros sistemas computacionais.
 - Alguns dispositivos chamados Sistemas Embarcados, na verdade, não os são.



EXEMPLOS E APLICAÇÕES



Market	Embedded Device
Automotive	Ignition System
	Engine Control
	Brake System (i.e., Antilock Braking System)
Consumer Electronics	Digital and Analog Televisions
	Set-Top Boxes (DVDs, VCRs, Cable Boxes, etc.)
	Personal Data Assistants (PDAs)
	Kitchen Appliances (Refrigerators, Toasters, Microwave Ovens)
	Automobiles
	Toys/Games
	Telephones/Cell Phones/Pagers
	Cameras
Global Positioning Systems (GPS)	



EXEMPLOS E APLICAÇÕES



Market	Embedded Device
Industrial Control	Robotics and Control Systems (Manufacturing)
Medical	Infusion Pumps
	Dialysis Machines
	Prosthetic Devices
	Cardiac Monitors
Networking	Routers
	Hubs
	Gateways
Office Automation	Fax Machine
	Photocopier
	Printers
	Monitors
	Scanners



EXEMPLOS E APLICAÇÕES

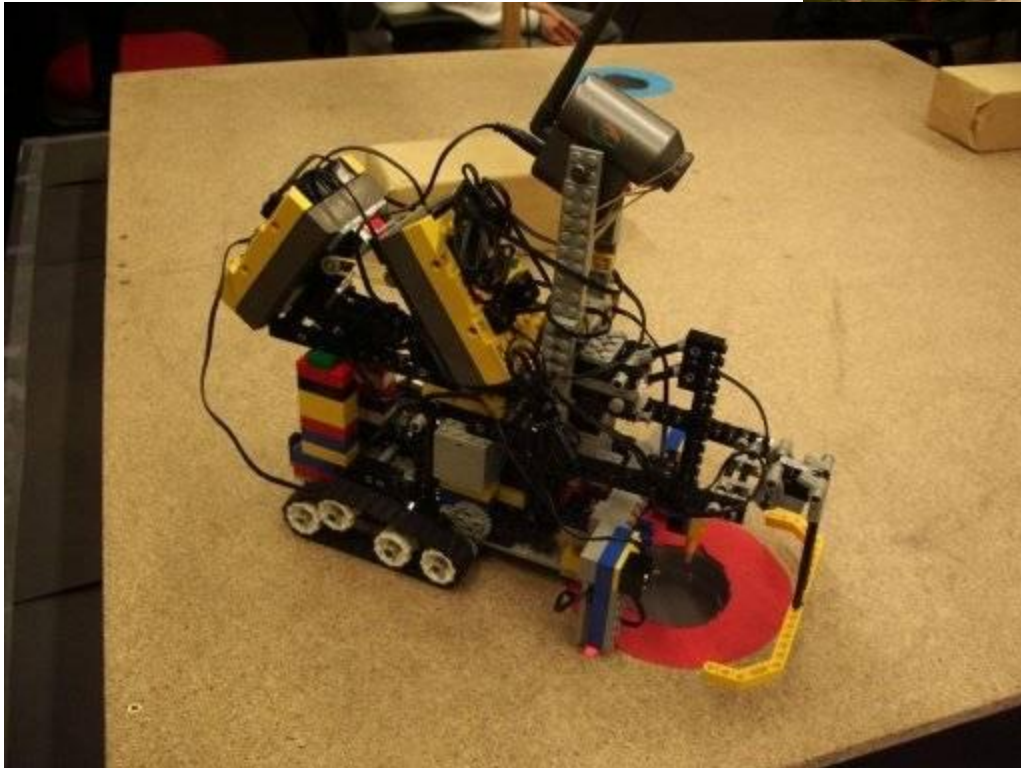

ARQUITETURA CONCEITUAL



- Modelo conceitual de arquitetura de Sistemas Embarcados:

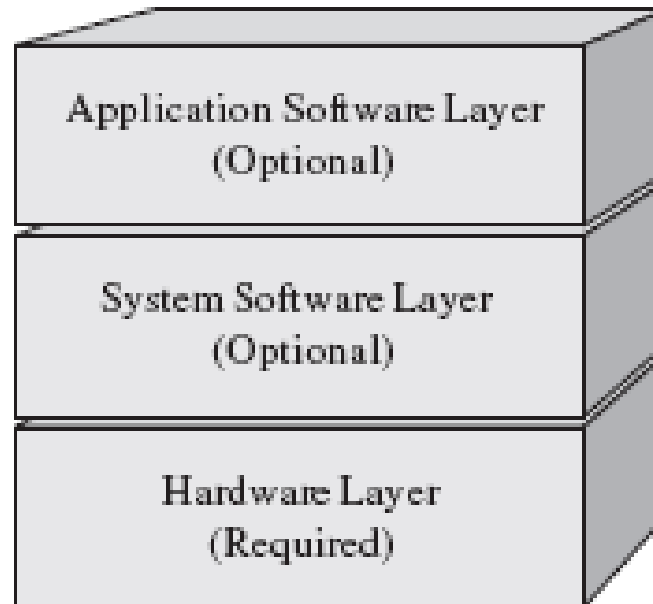



ARQUITETURA CONCEITUAL



- Camada de Hardware:
 - Processador Embarcado.
 - Memórias (ROM, RAM, etc.).
 - I/O:
 - Rede e comunicações (camada física do modelo OSI).
 - Input (teclado, mouse, controle remoto, vocal, etc.)
 - Gráficos e output (touch screen, CRT, impressoras, LEDs, etc.)



ARQUITETURA CONCEITUAL



- Armazenamento (discos óticos, discos magnéticos, fitas magnéticas, etc.)
- Depuração (BDM, JTAG, porta serial, porta paralela, etc.)
- Tempo real e outros
(temporizadores/contadores, conversores A/D e D/A, chaves lógicas, e por aí vai...)
- Barramentos (PCI, IDE, USB, SCSI...).

ARQUITETURA CONCEITUAL

- Exemplos:

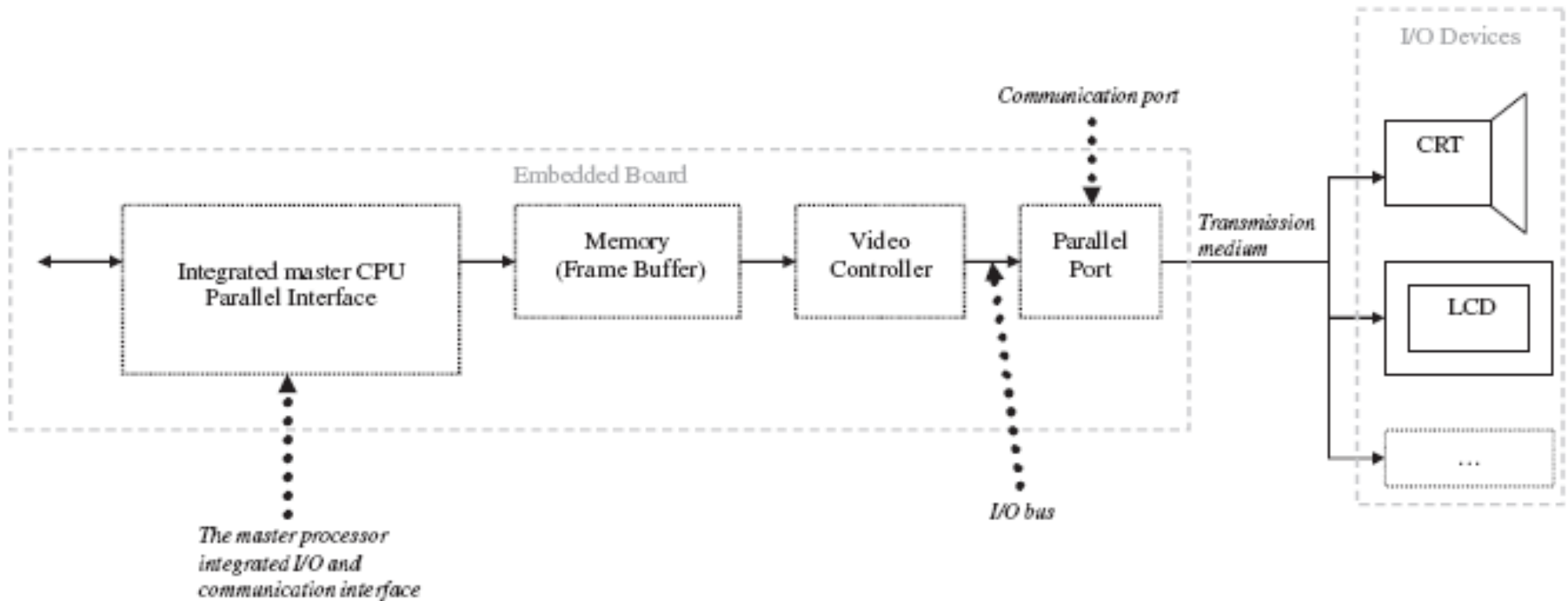

ARQUITETURA CONCEITUAL

- Exemplos:

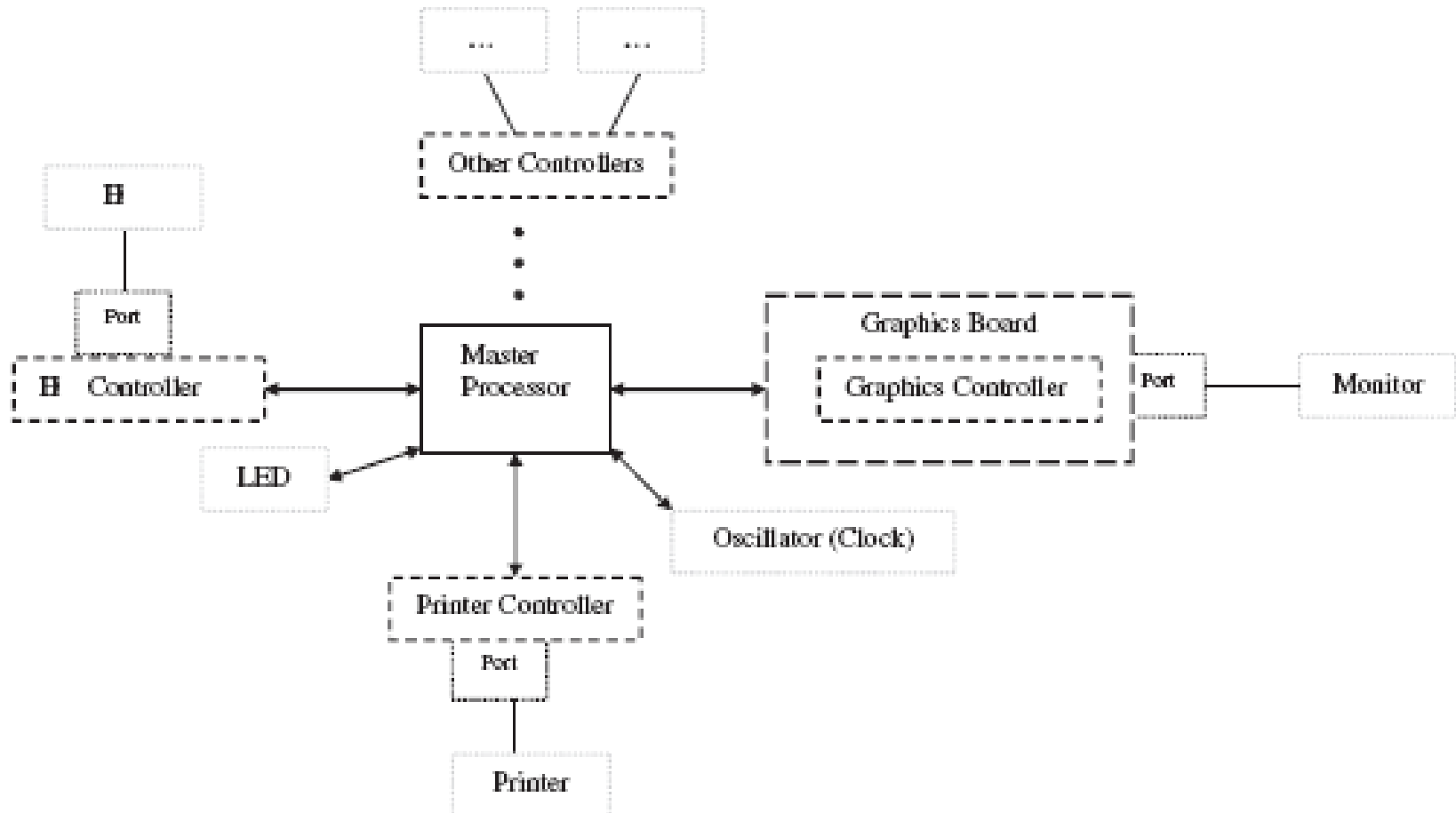

ARQUITETURA CONCEITUAL



- Camada de Sistema de Software:
 - Camada de Drivers de Dispositivos

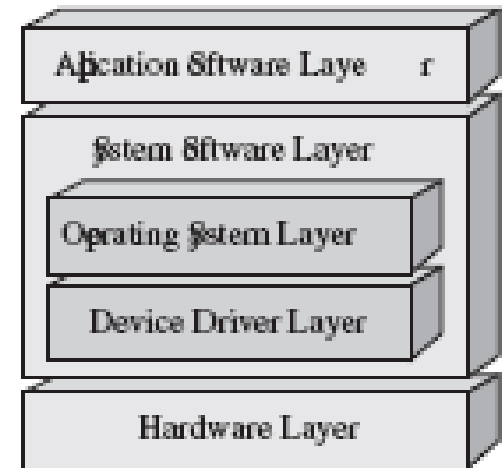
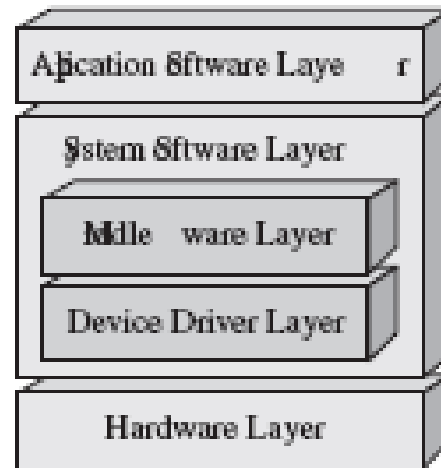
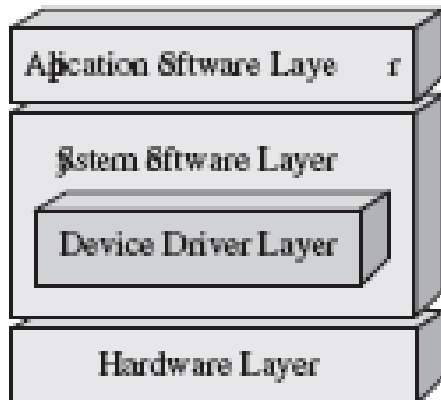

ARQUITETURA CONCEITUAL



- Drivers de Dispositivos é a biblioteca de software que inicializa o hardware e provê às camadas superiores acesso a ele.

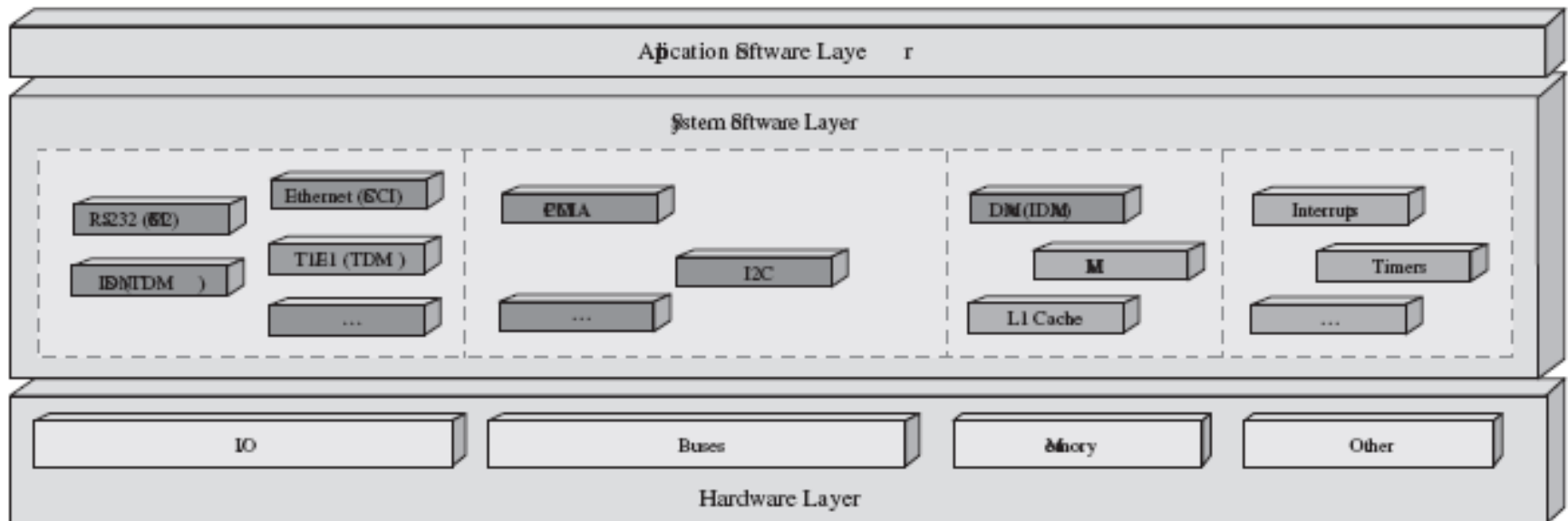

ARQUITETURA CONCEITUAL



- Camada de Sistema Operacional

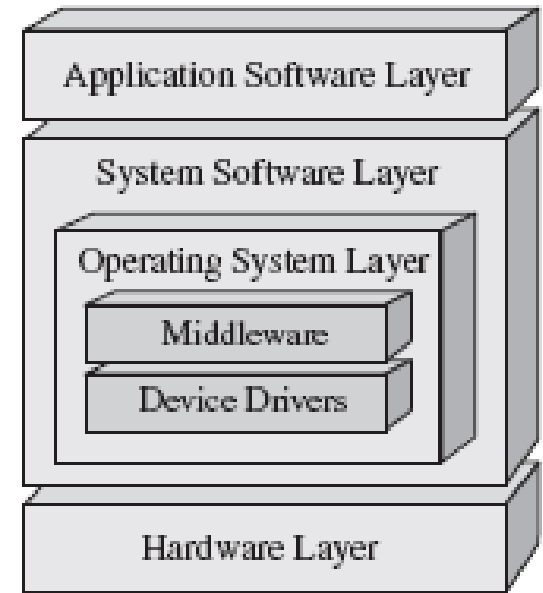
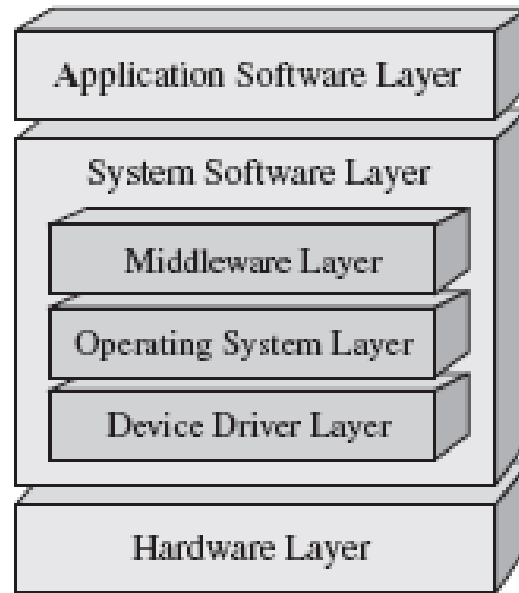
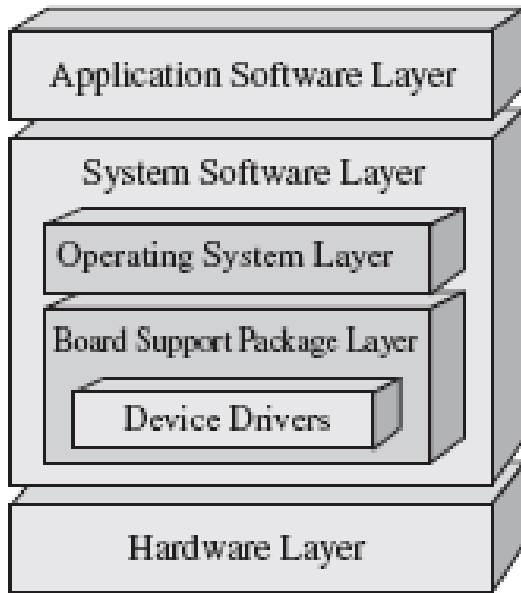

ARQUITETURA CONCEITUAL



- O SO é um conjunto de bibliotecas de software com dois propósitos principais em um Sistema Embarcado:
 - Provêr maior nível de abstração.
 - Gerenciar os vários recursos de software e hardware do sistema, através de um kernel (Gerenciamento de processos, memória e I/O).

NetBSD
Nucleus RTOS
OpenBSD
OSE
OS-9
Palm OS
QNX
RTEMS
RTXC Quadros
SymbianOS
ThreadX
T2 SDE
uKOS
Unison OS
VxWorks
Windows CE
Windows Mobile
Windows XP Embedded

DSPnano
DRYOS
eCos
Embedded Linux
embOS (Segger)
Forth
FreeDOS
FreeRTOS
Inferno
ITRON
LynxOS RTOS
MicroC/OS-II
MicroSuse

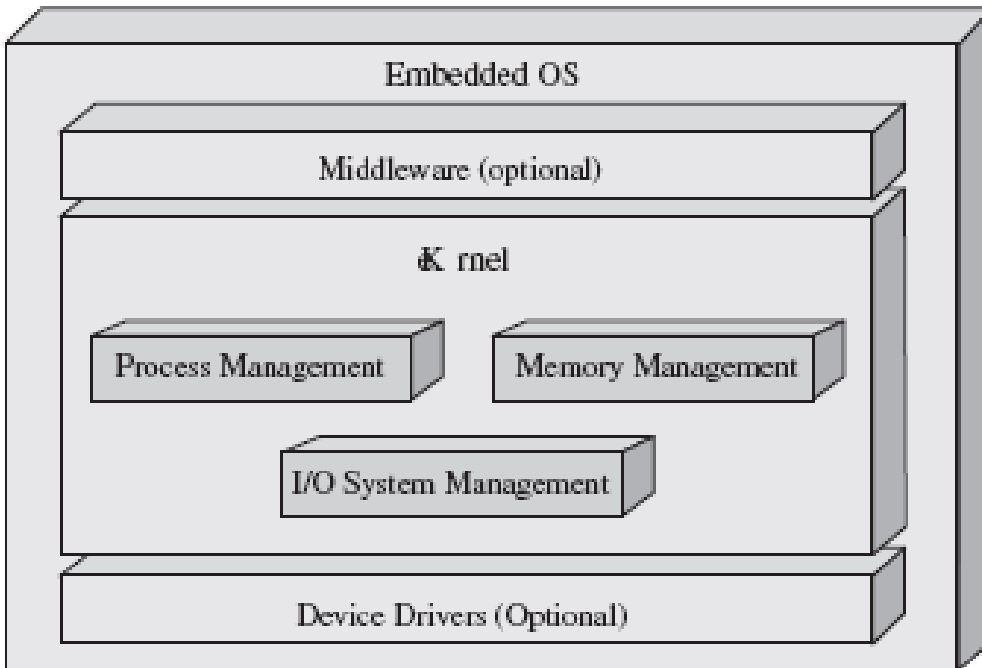

ARQUITETURA CONCEITUAL



- Camada de Middleware

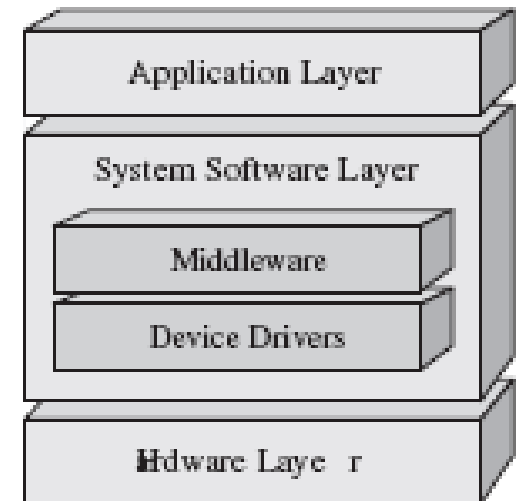
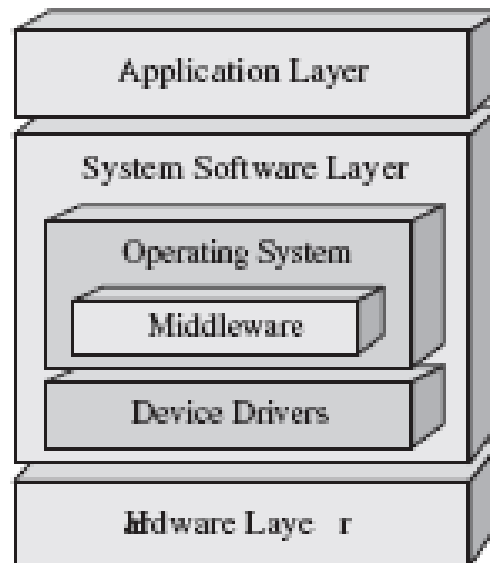
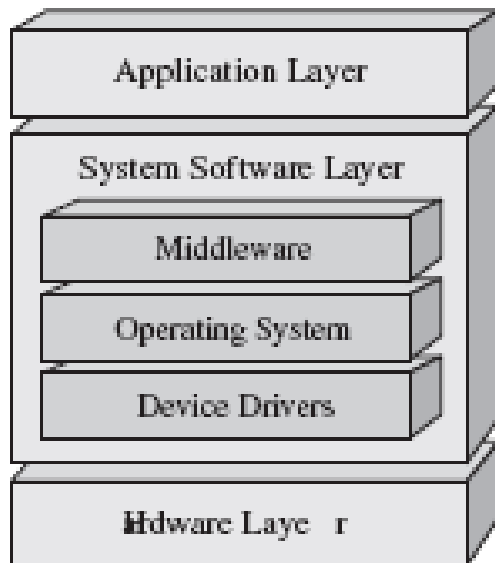

ARQUITETURA CONCEITUAL



- Middleware é geralmente o software que faz a mediação entre software de aplicação e kernel ou drivers de dispositivos.

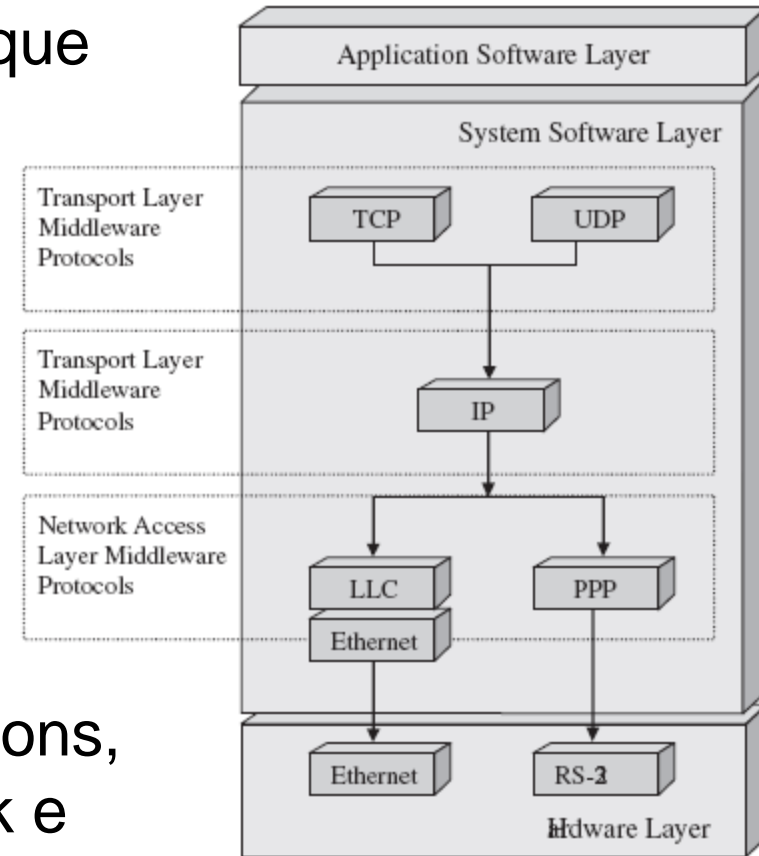

- Exemplos: Sun embedded Java solutions, Microsoft's .NET Compact Framework e CORBA do Object Management Group (OMG).

ARQUITETURA CONCEITUAL



- Camada de Aplicação

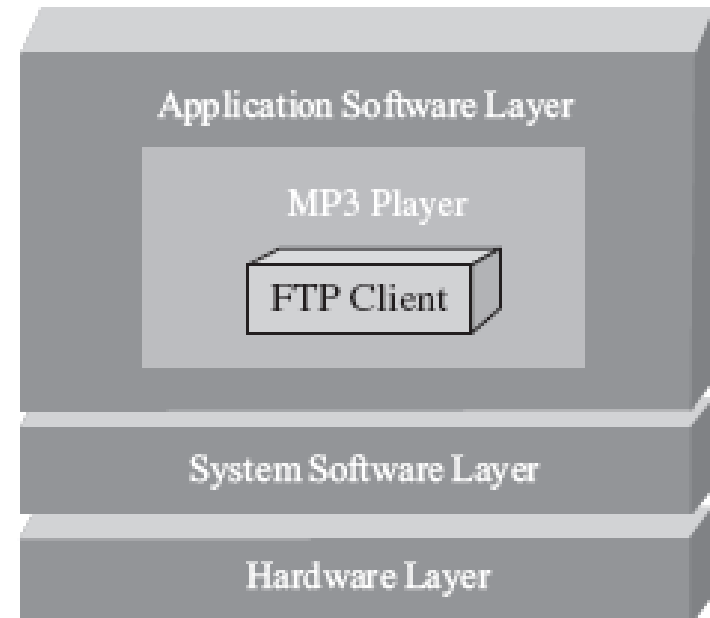
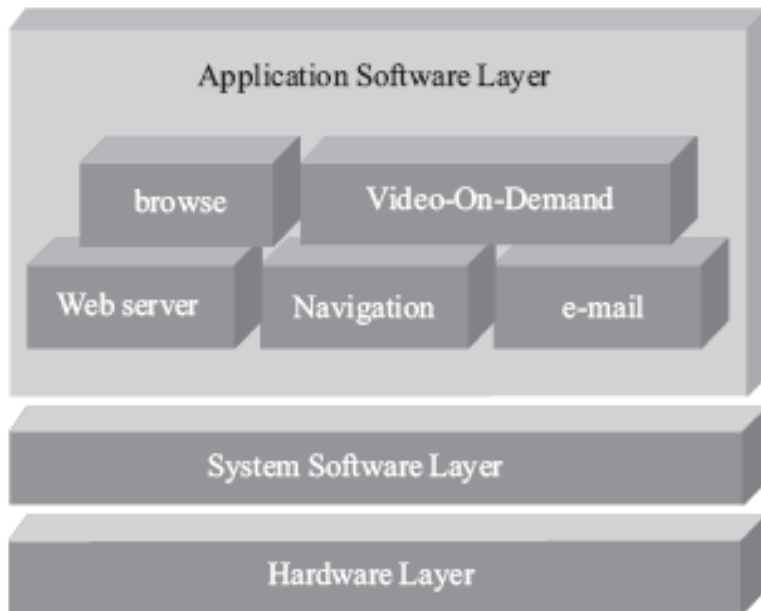

ARQUITETURA CONCEITUAL

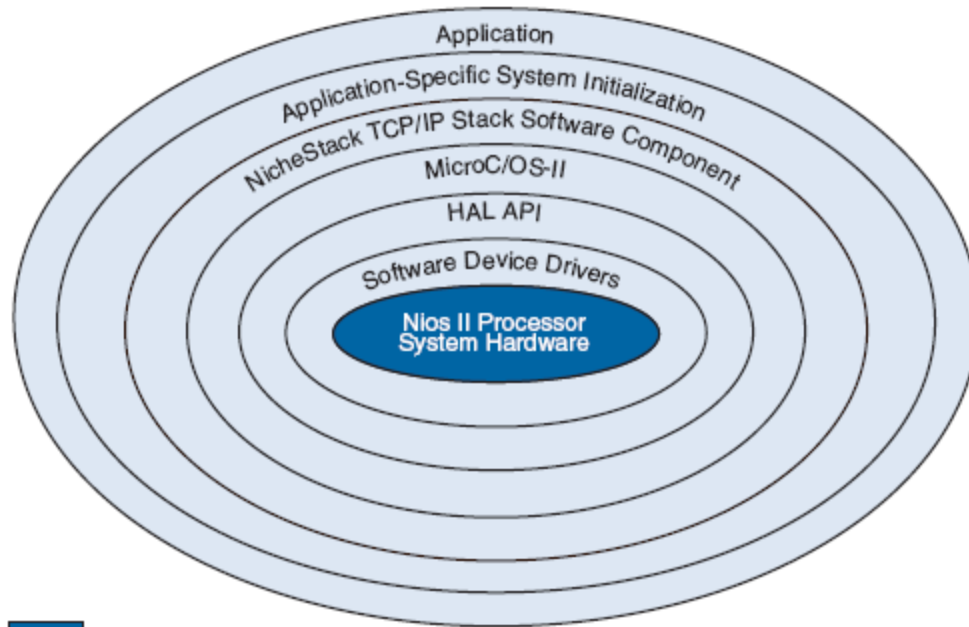

 Hardware
 Software

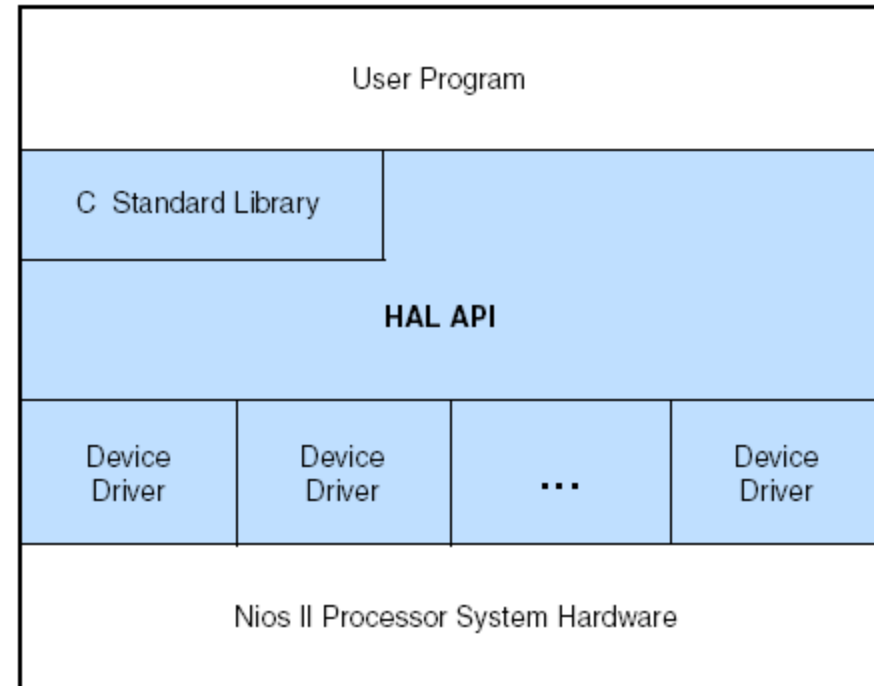

ARQUITETURA CONCEITUAL

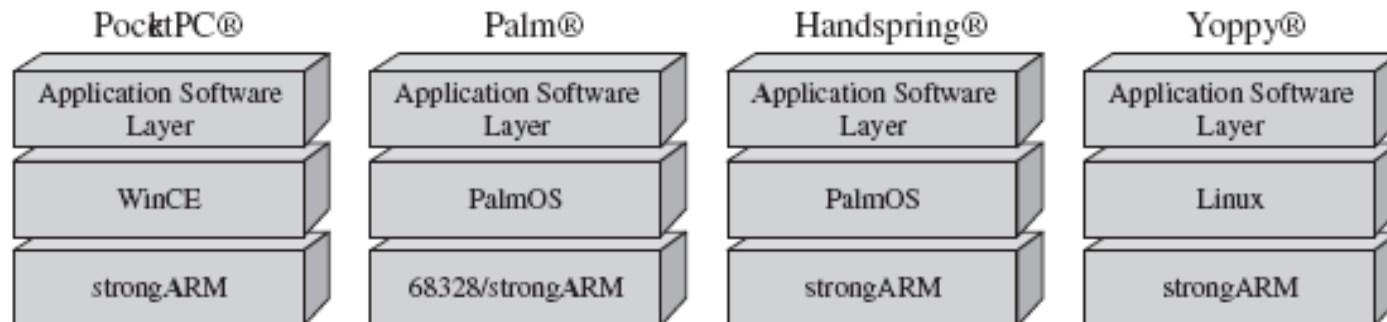
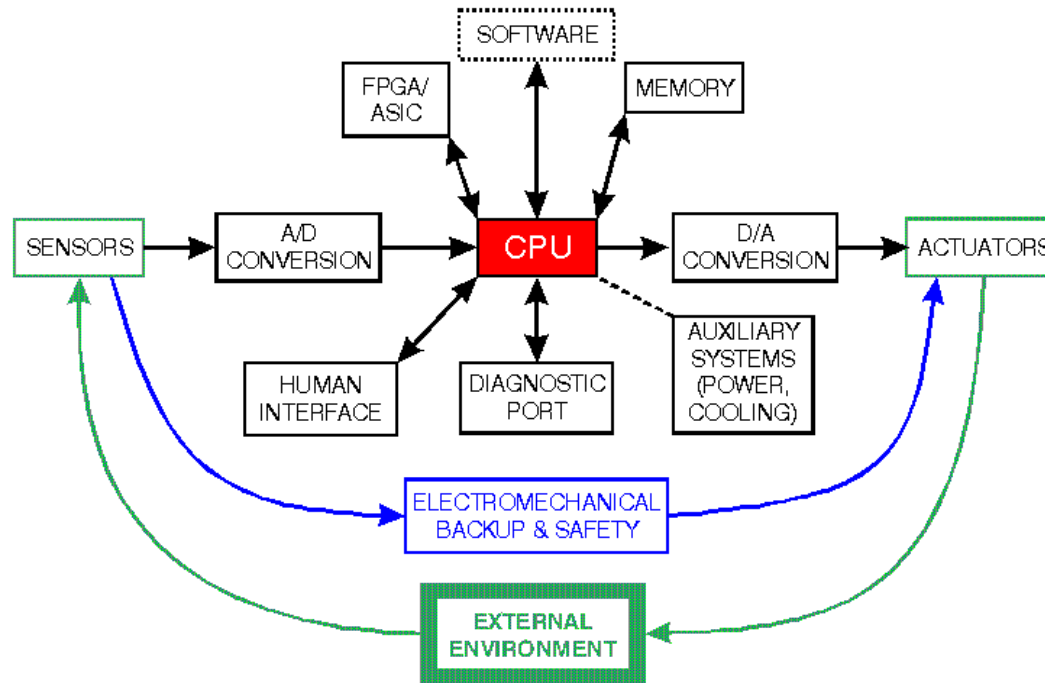

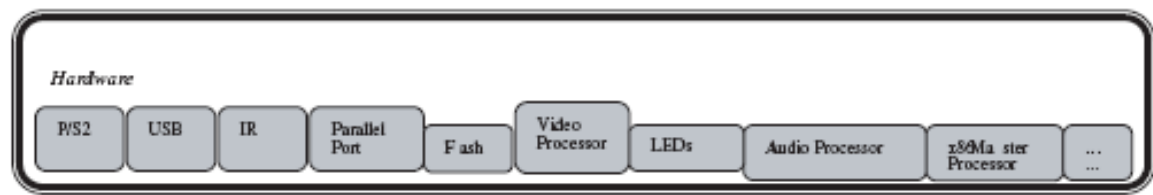
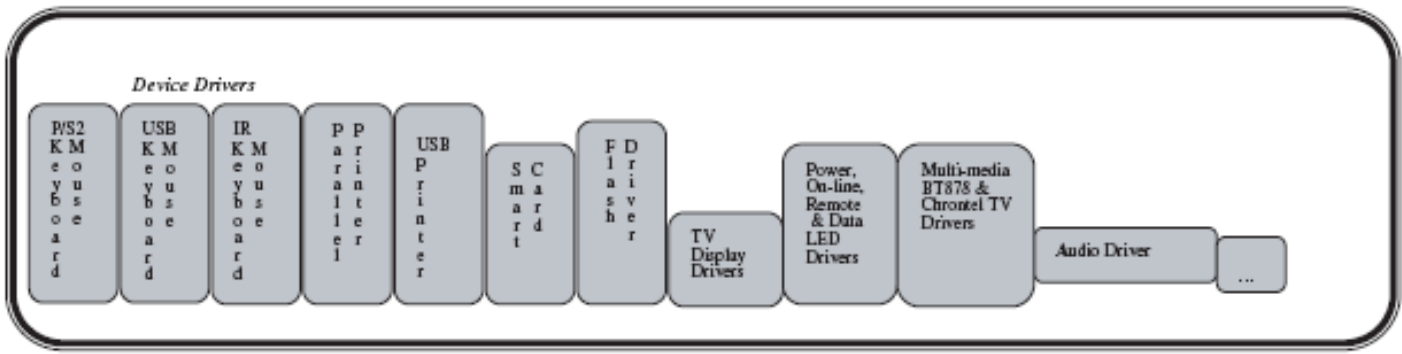
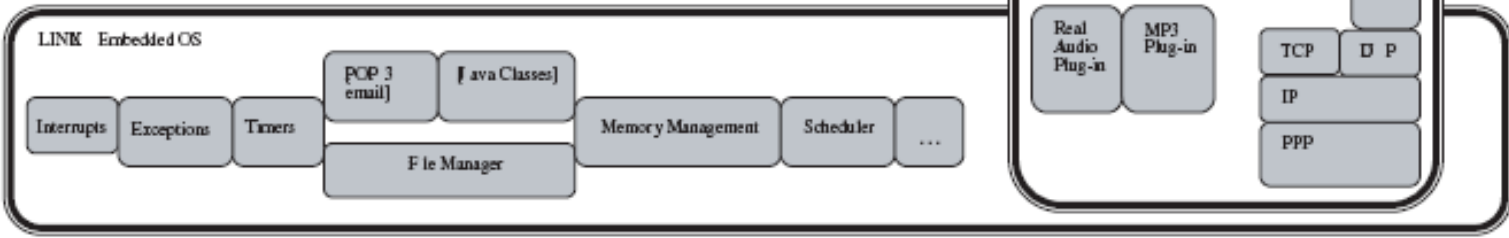
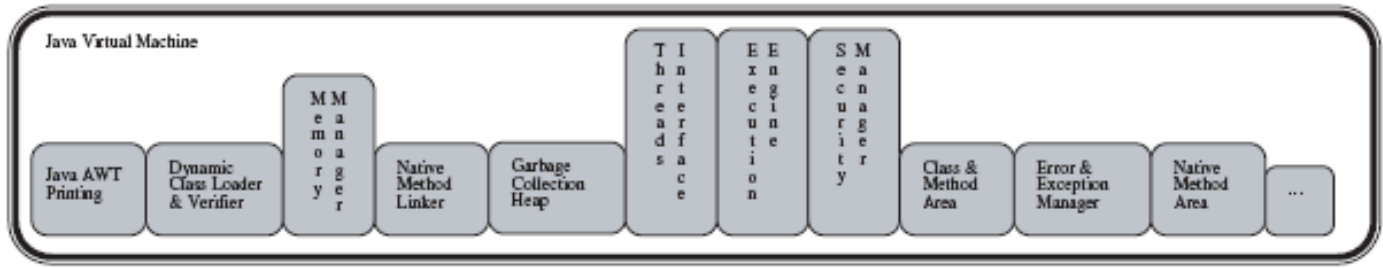

IMPLEMENTAÇÃO DE PROJETOS



Hardware

Ferramentas CAD.

- Descrição em HDL, Síntese e Simulação de lógica digital.
- Geração de sistemas inteiros a partir de módulos IP (Intellectual Property).

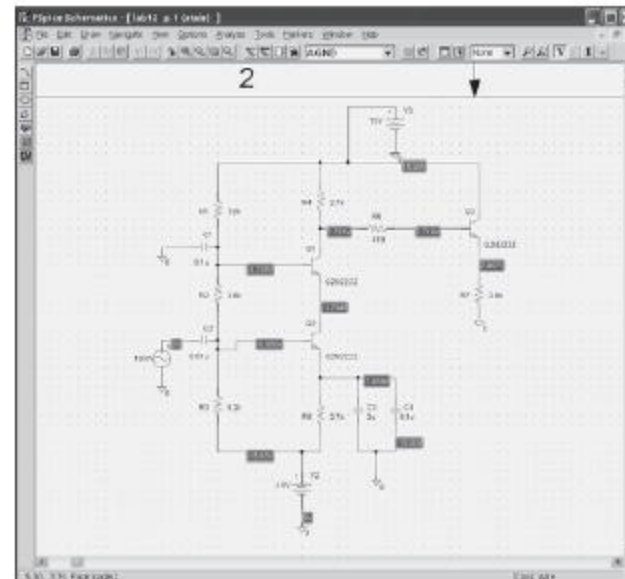
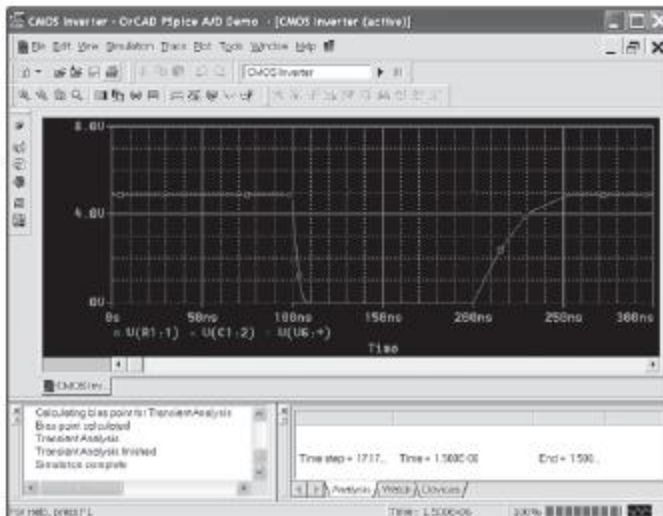

IMPLEMENTAÇÃO DE PROJETOS



- Utilização de kits de prototipação.
 - Dispositivos programáveis (FPGA, CPLD...)
 - Elementos de hardware (USB, Ethernet, PCI, LEDs, Botões, LCD, Display de 7 Segmentos...).
 - Depuração a nível de software através de portas de comunicação.

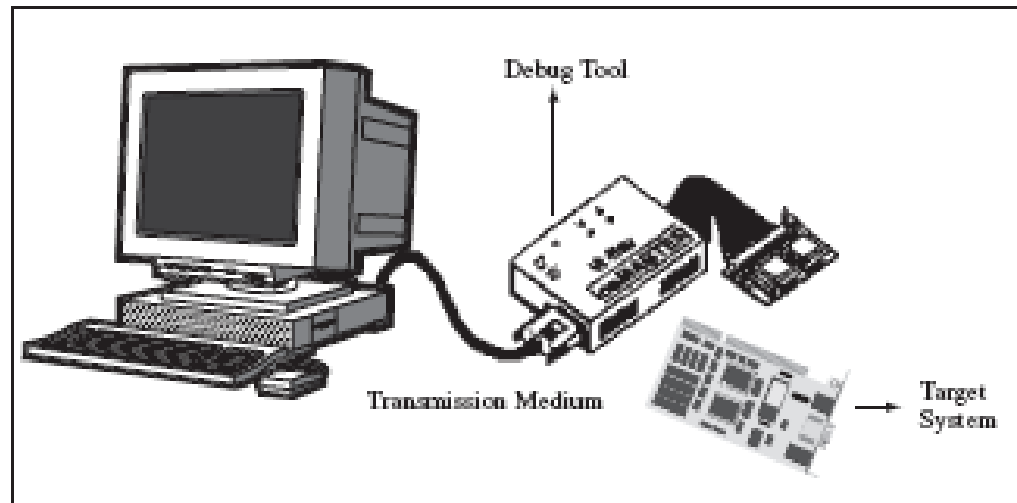
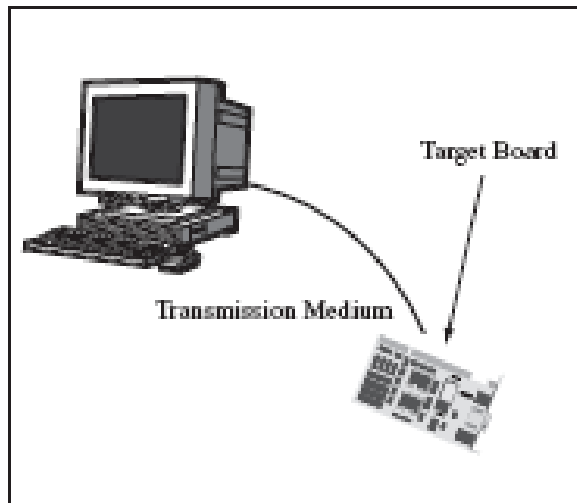

IMPLEMENTAÇÃO DE PROJETOS



Software

- Suporte a vários tipos de Linguagens de Programação (C/C++, Ada, Java...)
- Utilização de IDEs
- Simulação em ISS (Instruction Set Simulator)
- Execução integrada com kit de prototipação.

```
compiling
"F:\jbed\Java\Lib\com\jbed\examples\helloworld\HelloWorld.java"
image size: 835552 bytes
file size: 2086908 bytes
sending F:\jbed\Java\Lib\Boot.txt..... ek
Hello World

// HelloWorld.java
// jbed HelloWorld Tutorial Program

package com.jbed.examples.helloworld;

public class HelloWorld{

    private static int count = 0;    // loop counter
```

```
public class HelloWorld{
    private static int count = 0;
    // loop counter
}

// HelloWorld.java
// jbed HelloWorld Tutorial Program

package com.jbed.examples.helloworld;

public class HelloWorld{
    private static int count = 0;
    // loop counter
}
```



FUTURO DOS SISTEMAS EMBARCADOS



- Hoje, os embarcados marcam forte presença no nosso dia-a-dia.
- Muitas vezes eles estão “transparentes” e nós não os percebemos.
- Assim eles têm ganhado cada vez mais espaço na academia e na indústria.
- Adquiriram uma importância indiscutível.



FUTURO DOS SISTEMAS EMBARCADOS



- Apesar da facilidade de desenvolvimento, os projetistas tem se preocupado com projetos de sistemas embarcados cada vez maiores.
- Ramo muito promissor para os novos profissionais, envolvendo conhecimentos desde da física de semicondutores até a engenharia de software.



FUTURO DOS SISTEMAS EMBARCADOS



- A tendência é a adição de mais inteligência a processos e produtos, e maior conectividade, através de tecnologias de rede sem fio, por exemplo.
- O mercado de embarcados é aproximadamente 100 vezes maior que o de desktops e deve crescer exponencialmente na próxima década.

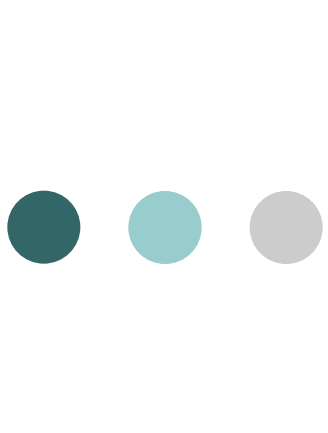

THE END

